

# Harlequin® HydroClear

SEWAGE TREATMENT PLANT

INSTALLATION AND  
OPERATING INSTRUCTIONS

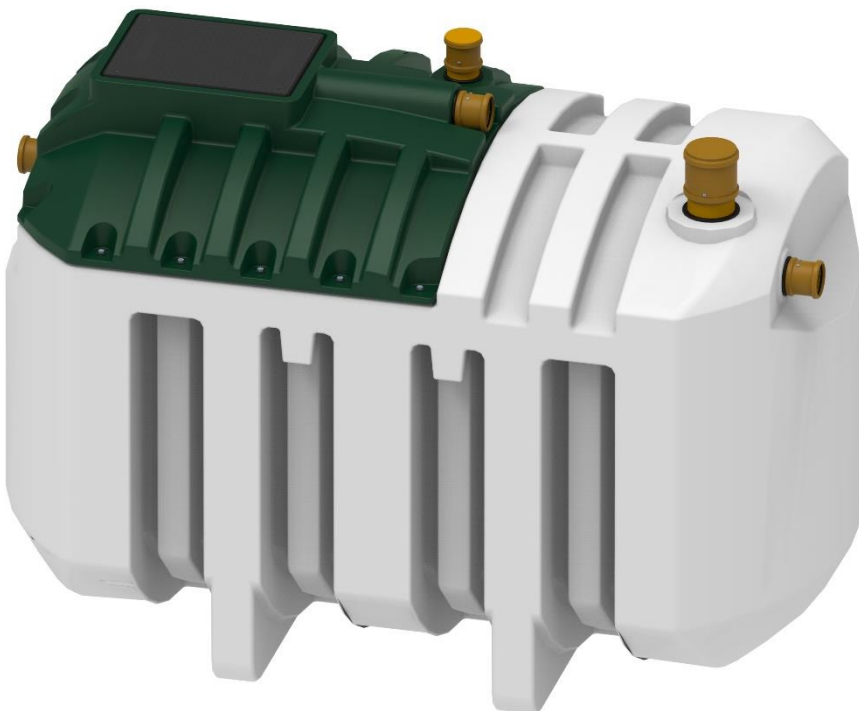

**NEW HC6 &  
HC8  
RELEASED  
JAN 2021**

**IMPORTANT: Please see  
updated installation  
instructions for new models**

*An environmental asset*

**Harlequin®** **CE**  
MANUFACTURING FOR TOMORROW

## Contents

Harlequin HydroClear Key Data	3
General Information	4
Regulations and General Guidelines	4
Plant Siting	5
Installation Instructions **	6
Operating Instructions	11
Desludging and Servicing	13
Maintenance Schedule	14
Installer Check-List	15
Fault Finding	16
Appendix 1: Certification	17
Appendix 2: Hydroclear Mk II Installation Guidelines **	18
Appendix 3: Service History	19

\*\* - Installation Instructions for new HydroClear 6 and HydroClear 8 models have been modified. Please refer to Page 7 & Appendix 2 for Detailed Instructions. This procedure **MUST** be followed, or your warranty will be void

Harlequin HydroClear key data.

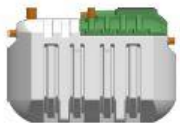

Figure 1: HydroClear 6 Pop

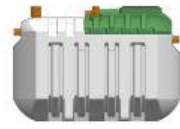

Figure 2: HydroClear 8 Pop



Figure 3: HydroClear 12 Pop

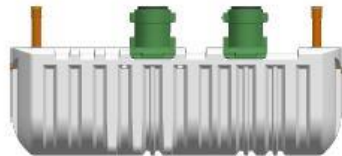

Figure 4: HydroClear 20 Pop

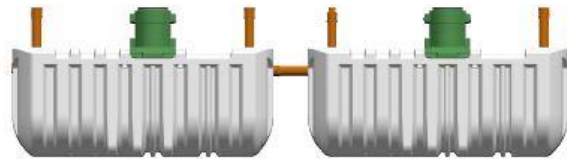

Figure 5: HydroClear 30 Pop

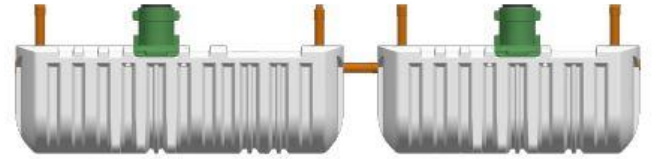

Figure 6: HydroClear 40 Pop

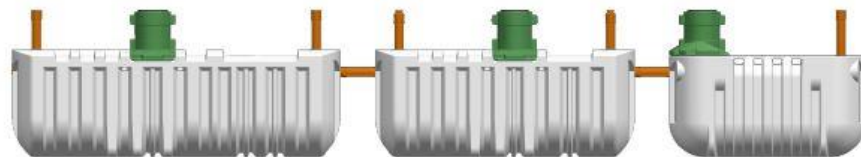
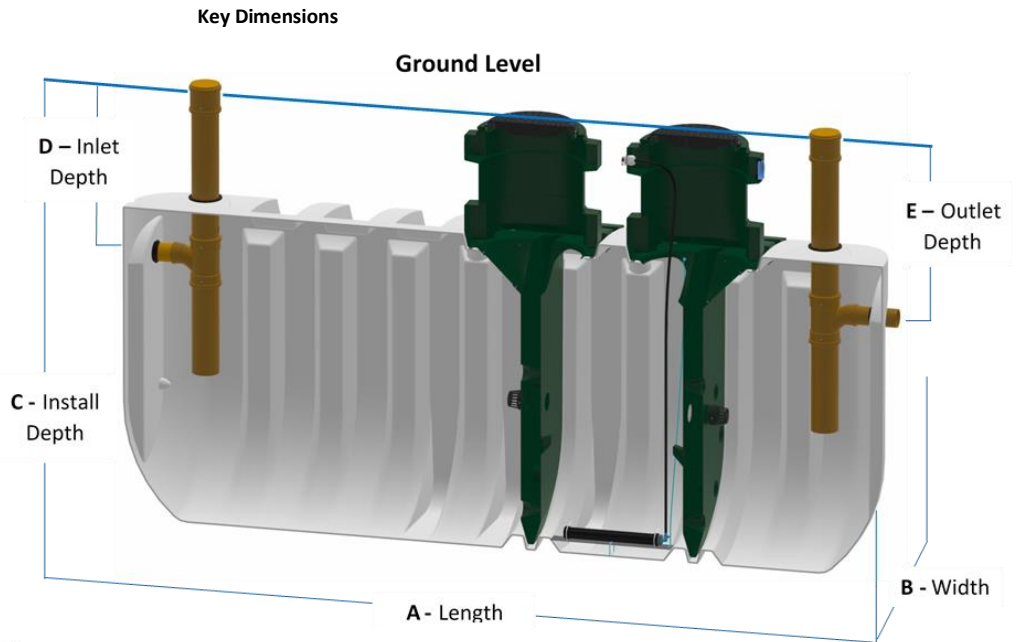

Figure 7: HydroClear 50 Pop



Key Dimensions

P.E.	Total Cap.	Tank 1					Tank 2					Tank 3				
		A	B	C	D	E	A	B	C	D	E	A	B	C	D	E
6	4770	2900	1620	2000	500	630										
8	4770	2900	1620	2000	500	630										
12	5950	4500	1400	2560	1090	1140										
20	7960	5680	1400	2560	1090	1140										
30	11410	4500	1400	2560	1090	1140	4500	1400	2560	1140	1140					
40	14920	4500	1400	2560	1090	1140	5680	1400	2560	1140	1140					
50	18400	5680	1400	2560	1090	1140	4500	1400	2560	1140	1140	3400	1250	2560	1140	1140

## General Information

### Introduction

It is strongly recommended that you read all sections of this manual before installing and operating your new Harlequin HydroClear. Some installation and operation requirements are specific to HydroClear products and it is important to familiarise yourself with these.

***This information is supplied as a best practise guide and it is the responsibility of the user/installer to verify that it is used appropriately for the ground and load conditions.***

***Installation of the equipment should only be undertaken by a qualified specialist who is covered with professional indemnity insurance.***

### End-user responsibilities

It is the end-user's responsibility to ensure that their drainage and sewage treatment system complies with statutory requirements and does not cause pollution to the environment. Guidance can be found at Planning & Building Control departments as well as environmental agency offices regarding statutory obligations.

A professional consultant (architect/consulting engineer/drainage consultant) with experience in off-mains systems should be appointed to carry out a detailed site assessment evaluation and design of the groundworks. In addition, the following requirements must be met:

- ***The plant must be installed, operated and maintained in accordance with the requirements of this document***

The Harlequin HydroClear is designed to provide full treatment of normal domestic wastewater to discharge direct to surface waters, removing the need for a soakaway system (subject to a "Consent to discharge" license).

The discharge from a treatment plant will require a Discharge Permit from the Environment Agency if the volume of discharge is greater than 5.0m<sup>3</sup>/day direct to watercourse or 2.0m<sup>3</sup>/day to soakaway, which must be obtained before installation.

In all cases, approval should initially be sought through the local authority Building Regulator. It may also be necessary to obtain the consent of:

- The Environment Agency (EA - England and Wales)
- The Scottish Environment Protection Agency (SEPA - Scotland)
- Environmental Protection Agency (EPA - Ireland)
- The Northern Ireland Environment Agency (NIEA)

### Health and Safety

The advice given in this document is provided with your safety in mind. This document should be retained for future reference and remain in the household should a new occupier take ownership. The following health and safety guidelines should always be strictly adhered to in relation to the operation and maintenance of any wastewater treatment plant. It is important that:

- ***All electrical work is carried out by a qualified electrician***
- ***All plumbing work is carried out by a qualified plumber or groundworks engineer***
- ***All maintenance activities include appropriate measures to safely isolate electrical and water sources.***

At all times, safe working practices should be observed and adopted to avoid accident and injury when working with the equipment.

- The site should preferably be fenced off to prevent unauthorised access, particularly for small children
- The air blower housing should be kept closed at all times when in operation
- The manhole covers should never be removed and left unattended, even during service visits
- The air blower housing contains electrics operating at 240v. All equipment must be isolated before any maintenance is carried out
- Misuse can lead to serious injury and damage to the plant
- Protective clothing and gloves should be worn at all times and careful attention paid to personal hygiene, especially if there is any potential contamination with sewage products
- Medical attention must be sought if a user is feeling unwell after coming into contact with wastewater products

Leaving the tank unattended during servicing should be strictly discouraged in accordance with the health and safety procedures.

**Warning: Wastewater treatment processes can produce hazardous gas concentrations even when vessels are fully drained. Never enter vessels without appropriate training and protective equipment.**

### Maintenance

It is important to note that it is the end user's responsibility to ensure that maintenance is performed on the system at the appropriate period. Maintenance will ensure good operation and avoid breakdown which could lead to environmental pollution. Environmental enforcement agencies responding to pollution will hold the owner of the system responsible for ensuring compliance with any consent parameters imposed on the site.

The Maintenance and Service requirements for the HydroClear products start from Page 13 of this document. The Warranty for the product will be dependent on all the installation and servicing guidelines being followed.

### Regulations and Guidelines

The following documents provide guidance on the requirements of design and installation of wastewater treatment plants.

#### Publicly available guidance documentation

- Northern Ireland Environment Agency Water (Northern Ireland) Order 1999 (97.5%)
- The Environmental Permitting (England and Wales) Regulations 2016

- The Water Environment (Controlled Activities) (Scotland) Regulations 2011
- Building Control Regulations 2010, part H Drainage and Waste Disposal, 2015 edition
- British Water Flows and Loads – 4, Code of Practice

### Relevant Design and Testing standards

- EN 12566-3:2005+A2:2013
- BS 6297:2007+A1:2008

### Tank sizes and construction

The Harlequin HydroClear is produced in seven sizes - 6, 8, 12, 20, 30, 40 & 50 populations - and are rotationally moulded in tough polyethylene which offers a very high level of impact resistance.

### Tank design features

The tanks have moulded-in lifting slots for use during handling and installation. NB: *only to be used when the tank is empty*. NOT on the HC6/HC8 version

Secure pedestrian duty manhole covers are supplied as standard to comply with statutory regulations.

The tanks have an engineered flat base for stability during transportation and storage prior to installation.

### Storage prior to installation

Tanks should be set on a smooth level base and securely tied or propped to prevent them from overturning and causing damage or injury.

### Handling

The rotationally moulded polyethylene tanks should be handled by crane or other designated and suitably rated lifting equipment using the moulded lifting slots provided (only when empty). Please contact Harlequin if you require specific product drawings and dimensions of your product.

Harlequin Manufacturing Ltd can accept no responsibility for incorrect offloading or installation. The contractor is responsible for offloading all items of equipment with due regard to the following:

- DO NOT use chains or wire ropes.
- DO NOT lift the tank if it contains any water.
- DO NOT subject the tank to sharp impacts.
- DO check that all items delivered correspond with the delivery note.

When working in deep excavations, make sure that all necessary safety precautions are taken to ensure the stability of the excavation and provide safe working conditions for site personnel. The only time anyone needs to be working at the bottom of the excavation is when levelling the base and ensuring that the first backfill is correctly placed.

### Plant Siting

The discharge from a wastewater treatment plant should be sited a minimum of 10m from any watercourses or other buildings. The distance of the plant from properties may vary from area to area but attention should be paid

to the invert on the tank, the subsequent drain gradient on the inlet pipework and the potential of superimposed loads. Local building control office advice should always be sought through planning permission, where required.

The direction of the prevailing wind should also be taken into account when considering the plant location as odours may be present when the plant is being desludged or during maintenance. No odour should be present around the tank under normal operation providing the plant has been installed with the venting system (see 'ventilation' on page 11) and the plant has been correctly sized and installed.

For installation, consider the space required on site to allow an excavator to operate; for the removal of soil, delivery of concrete, gravel, etc. For maintenance, consider the access space required for a sludge emptying tanker. Maximum distance of 20m is needed to ensure hose length is sufficient.

Approval for the tank position should always be sought from the controlling authority at an early stage and planning signed off by the local authority building inspector prior to installation.

If using a drainage field, attention is drawn to the minimum recommended distances to other buildings and sources of water which may affect your plant location:

- Drainage Field from habitable dwelling = 15m
- Drainage Field from water course = 10m
- Drainage Field from well/drinking water source = 50m

### Drain gradients

Drain gradients from the dwelling to the treatment plant should be 1:40, although 1:80 can sometimes be permitted with approval of Building Control Officer. The gradient of pipes within a drainage field, if applicable, must be <1:200. The drain from the plant to the start of the drainage field should be in the range 1:40 to 1:80. These are only typical recommendations and must be approved by the Building Control Officer for specific sites.

### Ground and drain levels

Site plans should show existing and proposed ground levels and invert depths of the drain throughout its length. If the drain is too shallow, or if it passes under walls and foundations, it should be protected by concrete surrounds.

### Percolation tests and drainage fields

A soil percolation test should be carried out over the proposed drainage field where necessary. The calculations and drainage layout plan must be submitted to the Council Building Control dept along with the other drawings. The percolation tests should be carried out by a qualified specialist consultant who should be covered with professional indemnity insurance.

**Superimposed loads/protected areas**

Harlequin does not recommend that superimposed loads, such as vehicles, be allowed within 3m of any part of the tank.

The tank should not be situated close to a driveway or roadway, or anywhere there is a risk of it being subjected to additional superimposed loads. The protected area should also be fenced off.

If vehicular or other superimposed loads are required to come within the protected area a qualified civil/structural engineer must be employed to design the installation. This design must prevent loads being transmitted onto the tank.

Harlequin Tanks may not cover the warranty for the tank body under superimposed load conditions; this responsibility must be covered by the civil/structural engineer. It is thus a requirement that the installation is signed off by this third party engineer.

**Installation instructions**

Before any tank is installed, appropriate ground condition checks should be made to determine the soil constitution, position of the water table and any flood possibility in the area.

These checks should be performed through test holes in the proposed area and checks with Building Control and the appropriate environmental regulator on any history of level alterations of the local water table. Once the site information has been gathered, the installation type can be selected as either 'Dry' or 'Wet' ground conditions. If there is any doubt as to the summer/winter water table level, etc, a Wet site installation must be selected. Failure to follow the guidance instructions during installation may render the warranty null and void.



**Figure 8:** Reduced Turret Height Image and Modifying the Tank Invert Level (NOT applicable to HC6/HC8 models )

**Modifying the tank invert depth**

For transport purposes, the tank turrets are reduced to their minimum height as shown in Figure 8 above (Pop 12 and above models only). The Invert level can be set by raising the turret height and secured by re-fixing the unit using stainless steel self-tapping screws. This joint should also be sealed to prevent water ingress into the unit using silicone.

The maximum invert depth can be increased using Ø450mm risers (450mm x 600mm risers for the HC6/HC8) but only if specific ground condition checks have been made and the installation appropriately modified. In a standard gravity feed HydroClear, there should be no more than three of the risers used. In the pumped outlet version (Pop 12 and above) we recommend no more than two to allow access to the submersible pump.

If you wish to increase the invert beyond those maximum number of risers (up to a 2.0m maximum invert), we recommend the use of 1200mm concrete rings above the

risers to allow access to the manhole cover of the tank. Installation for this situation should follow the Wet ground installation procedure. The concrete rings need to be fully supported and not transfer any weight to the body of the tank. You will also need to extend any vertical 110mm pipe to ground level to ensure desludge access to the various chambers in the tank. Ensure that rodding points are clearly distinguished from desludge points to prevent accidental removal of biomedica.

***Failure to adhere to these design parameters may cause severe structural damage to the tank and will render any warranty null and void.***

**Dry ground installation conditions**

A site is deemed as being dry when at no time does ground water rise above the base of the tank. This is a requirement throughout seasonal changes not just at the time of installation.

NB: If the complete surrounding soil structure is non porous, eg, clay, a danger exists of water pooling around the tank within the backfill. In this circumstance either a land drain should be installed to drain the installation to the base of the tank or the wet installation procedure should be used.

Provision should be made for temporary covers and fencing around the excavation site to comply with statutory health and safety requirements.

**Dry installation procedure**

Excavations should allow for a minimum thickness of 300mm pea gravel all round and 150mm thickness of concrete below the tank(s). Where difficult ground conditions are encountered, ie, in unstable ground or shrinking clay, etc, an additional depth of 250mm should be excavated below the tank to allow for hardcore and sand blinding to provide a firm base for the concrete bed.

Place wet concrete (slump test 30mm, strength 25N/mm<sup>2</sup>) in base of the excavation to a depth of 150mm, grade and level to within 20mm. The concrete must extend a minimum of 300mm all round from the vertical sides of the tank(s). **This is vital to ensure a stable base to prevent settling of the tank(s) which could damage the pipe connections. Lower the tank(s) onto the dried concrete and check it is true and level using a spirit level.**

Fill the tank(s) to approximately 600mm water depth selecting specific product method as explained below:

**6/8 population units (HC6/HC8)**

*It is critical that the Reactor/media Chamber of this model is filled first when installing this tank. This will prevent*

*any buoyancy issues that **WILL** damage the tank. Once completed this will flow into the Final Settlement Chamber/Clarifier. The Primary tank may then be filled either through the inlet pipe or through the access/rodding point on the tank. Please refer to Appendix 2 for an illustrated guide on this.*

**12-50 population units (HC12-50)**

*Ensure that all compartments within the tank(s) have been filled to the required level through the access turrets. This will ensure that the full length of the tank is correctly weighted. The order in which the chambers are filled is not crucial.*

Next, place and consolidate additional concrete carefully under the lower radii of the tank(s). This will ensure they are correctly supported once installed. Do not use a vibrating poker.

Continue to fill the tank with water whilst simultaneously backfilling around the tank with 12-15mm pea gravel, ensuring the level of water in the tank is maintained at approximately 200mm higher than the level of backfill. This will maintain equal pressure inside and outside the tank and will prevent any chance of movement during installation. When the tank is full of water to the inlet/outlet height, connect the inlet/outlet pipes to the tank (as labelled) and continue to build up and around the tank with backfill to around 300mm above the body of the tank (100mm in the HC6/HC8 version).

**Pea gravel specification**

Pea gravel or crushed aggregate of uniform particle size 12- 15mm, free of sharp edges. Chemically inert, washed clean and free of contaminants.

**DRY GROUND CONDITIONS**

**Primary Desludge access**

**Pea Gravel Backfill**  
Complete at least 300mm above main body of tank (100mm above HC6/HC8)

**Inlet Pipe**  
(min 1:40 gradient)

**Wet Concrete bed embedded up around base Of Tank**  
(Dry or Wet)

**250mm Hardcore and Sand Binding as necessary**  
(Dry or Wet)

**External Blower Box**

**Tank Invert can be adjusted by reducing baffles and desludge**

**Manhole Covers**

**WET GROUND CONDITIONS**

**Complete to ground level with soil and/or flagstones**

**Concrete Backfill**  
Complete at least 300mm above main body of tank (100mm above HC6/HC8)

**Outlet Pipe**  
(Gravity Version – min 1:80 gradient)

**300mm min backfill all around tank**  
(Dry or Wet)

**150mm thickness of concrete below the tank**

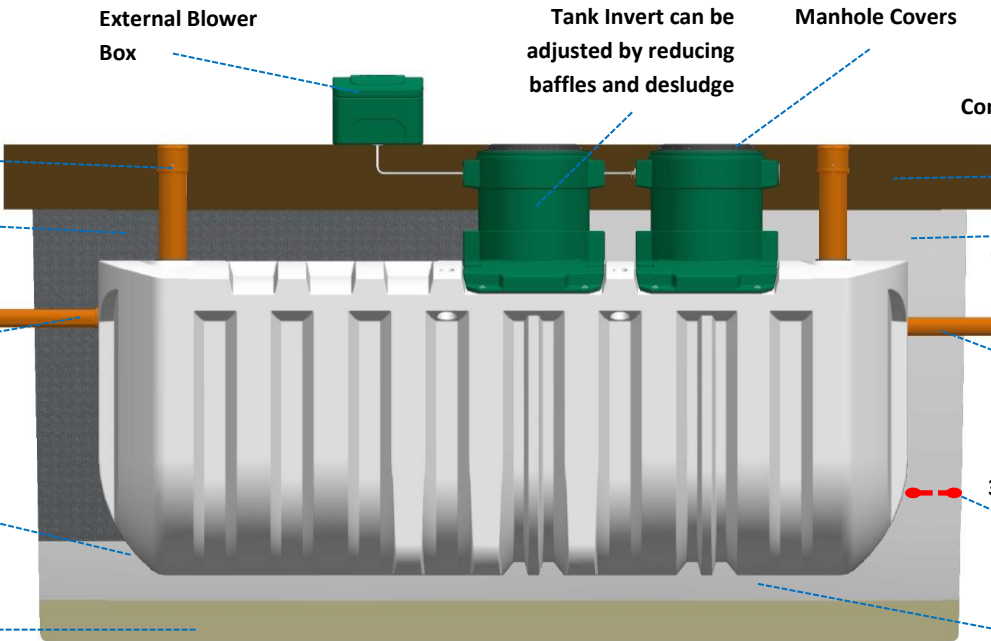

Figure 9: Typical Installation – Dry and Wet Ground Conditions (Pop 12 model)

**“Wet” ground installation conditions**

A site is deemed as wet when ground water can rise above the base of the tank. If in doubt of water table position, these Wet ground installation instructions must be followed.

**The maximum permissible water table level is 1.7m from the base of the tank(s). Failure to follow the guidance instructions during installation may render the warranty null and void.**

In poor soil conditions it is essential to make substantial provision for planking, strutting and temporary shuttering.

Adequate pumps should always be provided to keep the excavation free from ground water during the work. Provision should also be made for temporary covers and fencing around the excavation site to comply with statutory Health and Safety requirements.

**Wet installation procedure**

Excavations should allow for a minimum thickness of 300mm concrete all round and 150mm thickness of concrete below the tank. Where difficult ground conditions are encountered, ie, in unstable ground or shrinking clay, etc, an additional depth of 250mm should be excavated to allow for hardcore and sand blinding to provide a firm base for the concrete bed.

Place wet concrete (slump test 30mm, strength 25N/mm<sup>2</sup>) in base of the excavation to a depth of 150mm, grade and level to within 20mm. The concrete must extend a minimum of 300mm all around from the vertical sides of the tank(s). This is vital to ensure a stable base to prevent settling of the tank(s) which could damage the pipe connections. Lower the tank(s) onto the concrete and check it is true and level using a spirit level. Fill the tank(s) to approximately 600mm water depth selecting product specific method as mentioned above in the “dry” installation procedure

Next, place and consolidate additional concrete carefully under the lower radii of the tank(s). This will ensure they are correctly supported once installed. Do not use a vibrating poker.

Continue to fill the tank with water and carefully place concrete around the tank building up the layers, ensuring that there are no voids remaining around the tank. Do not use a vibrating poker. Ensure that the level of water inside the tank is maintained at a level approximately 400mm higher than that of the concrete backfill.

Fill the tank with water until it reaches the height of the outlet pipe and bring the concrete level up to within 400mm of this level. The concrete must now be allowed to harden – approx 24hrs. This is to prevent an unbalanced buoyancy force from the wet concrete from lifting the tank from the excavation as the backfill is raised above the internal water level.

Once the backfill concrete has hardened, connect the inlet/outlet pipes to the tank and continue to backfill with concrete, covering the top body of the tank by 300mm thick layer (100mm in the HC6/HC8)

**Electrical power requirements**

Power requirement is single phase 240V, through a 3-core steel wired armoured (SWA) cable. Refer to the Compressor specification supplied with your unit for the specific power ratings to size the electrical cable but 1.5mm is usually adequate. The supply to the unit should be by means of a dedicated circuit with isolation and protection devices consistent with the requirements for fixed equipment and in accordance with the latest regulations. The electrical installation of this equipment must only be carried out by a fully qualified electrician.

**Inside the External Blower Housing**

The standard external Blower Housing contains a linear diaphragm pump (air blower) pre-wired to a 20A Isolator (see Figure 10), 10m of airline hose and connection components for the airline and SWA power cable. The unit should be positioned close to the tank at ground level and this distance is limited by the length of airline provided. The perforated metal straps used for transport to hold the compressor in place should be removed prior to use.

We recommend shielding the blower box from direct sunlight as increased temperatures can reduce the lifespan of the diaphragms.

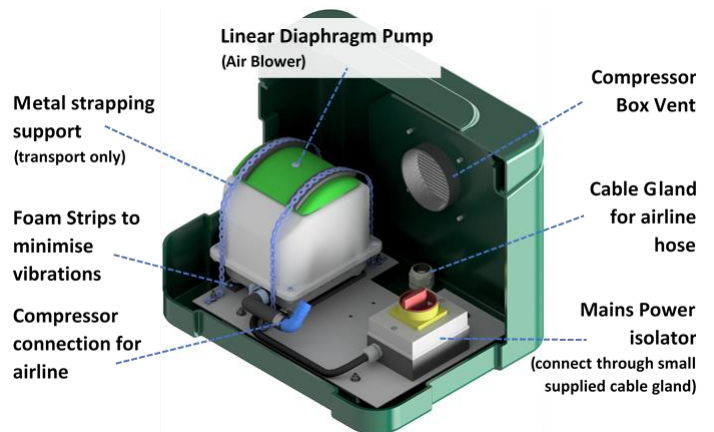

**Figure 10:** Inside the External Air Blower Housing

The mains power can be brought into the unit through the cable gland (supplied) with the drill location on the unit determined by the end user and then connected directly to the Isolator.

The incoming power supply to the tank must be installed with a separate earth leakage circuit breaker in the source building. Ensure the SWA cable is correctly installed, earthing the outer steel armouring at both ends. You can reduce the level of vibrations from the compressor unit by removing the perforated metal straps holding the unit down with the box. These are fixed to prevent movement during product transport.

**Connecting the airline to the tank**

The supplied airline should be fed through the large cable gland at the bottom of the unit (Highlighted in Figure 10) and connected to the blue plastic elbow/hose-tail on the air blower using a jubilee clip that comes in the kit.



The other end of the airline should be cut to length and joined to the airline installed on the tank using the straight connector and jubilee clips provided. This is carried out by cutting the end of the installed airline (shown Figure 11) and removing the linch pin and feeding back into the tank by loosening the large cable gland. You can then feed the main airline through the same cable gland and make the joint connection inside the tank body.

On the HC6/HC8 tank, all pipework/cables should be fed through the 110mm service duct connection at the top of the tank. These tanks also come fitted with a fixed pipe/hosetail connection for the airline just fitted below the manhole access lid



Figure 11: Tank External Airline Pipe (HC12 and above only)

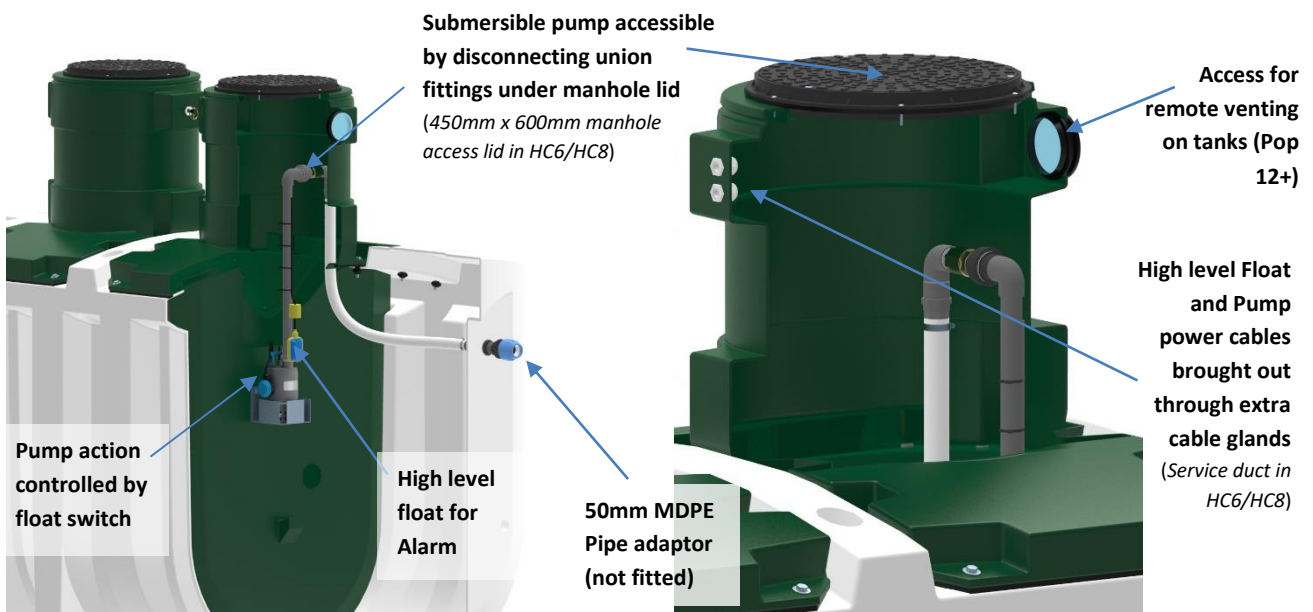

Figure 12: Tank Configuration in Pumped Outlet version (HC12 and above only)

**Pumped Outlet Version (Optional)**

Integrated pump outlets can be used where gravity drainage is not possible. The pump process operates through the submersible pump system situated in the Final Settlement Chamber, which is controlled with the use of a float switch. The float switch is set to turn on and off at predefined levels for pumping a specific volume of effluent out to a sample chamber or to discharge. This version of the product comes fitted with a 50mm MDPE Pipe Adaptor as an outlet connection on the tank as opposed to the standard 4" PVC pipe.

**Installation**

The pumped outlet version of the product should be installed physically by the same procedure as the standard tank. The cables for the high-level float and submersible pump should be brought out through the cable glands as shown in Figure 12 above to the external blower box. The submersible pump can be accessed in

the final chamber through the removal of the manhole access lid and disconnecting the union fitting as also shown in Figure 12. In the HC6/HC8 version, the submersible pump can still be accessed under the manhole access lid but it comes with a fixed pipe connection through to the outlet). All cables in the HC6/HC8 version should be brought out through the 110mm service duct.

The external blower box for this version will contain several extra fittings as highlighted in Figure 14 below. The cable for the high-level float should be connected to the Overflow Alarm Control box and the power connection from the submersible pump should be connected to the junction box within the blower chamber. We recommend installing a separate power connection/isolation for the Overflow Alarm Control in the External Blower Box to ensure continued operation in the event of a pump power failure (see Figures 15 & 16 below for schematics of the connections).

## HARLEQUIN HYDROCLEAR INSTALLATION AND OPERATING INSTRUCTIONS

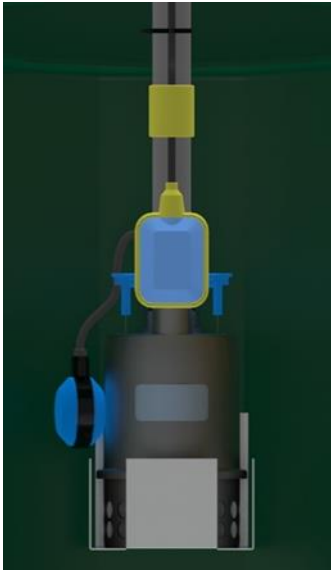

**Figure 13:** Pump and High-level Float Configurations in Pumped Outlet versions

The Submersible pump (Image in Figure 13) in the final chamber of the tank operates by use of an integrated float switch. As the water level rises in the final chamber, the float will rise above the pump handle and activate the pump. The pump will then switch off when the water level drops again.

The high-level float is attached to the outlet PVC piping connected to the submersible pump. This switch activates the alarm in the blower box (Figs 14-16) and is designed to only be triggered when the water level rises towards the top of the inner chamber (failure of the pump). If the alarm activates while the pump is operating, the float has been installed too low on the pipework. Please check the operation of all floats when installing.

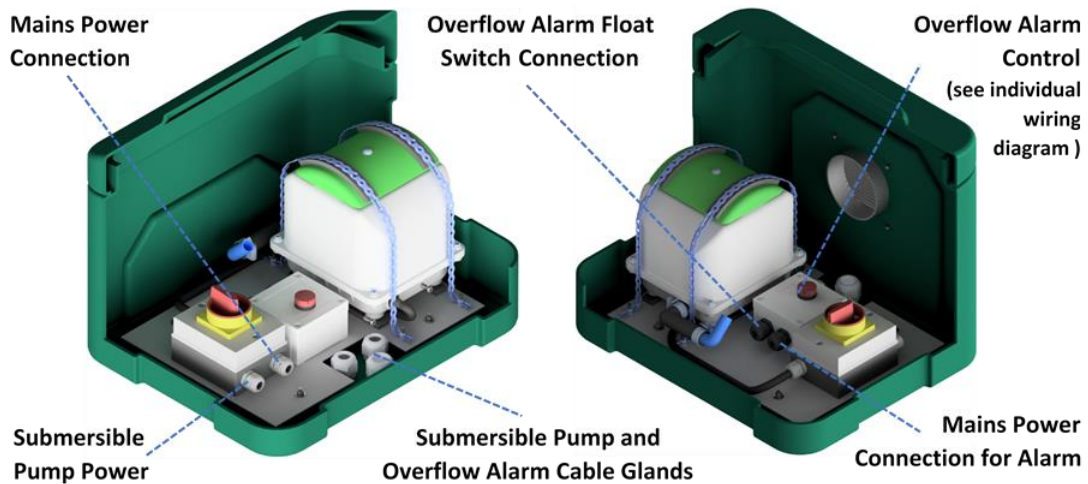

**Figure 14:** External Blower box assembly (Pumped Outlet version)

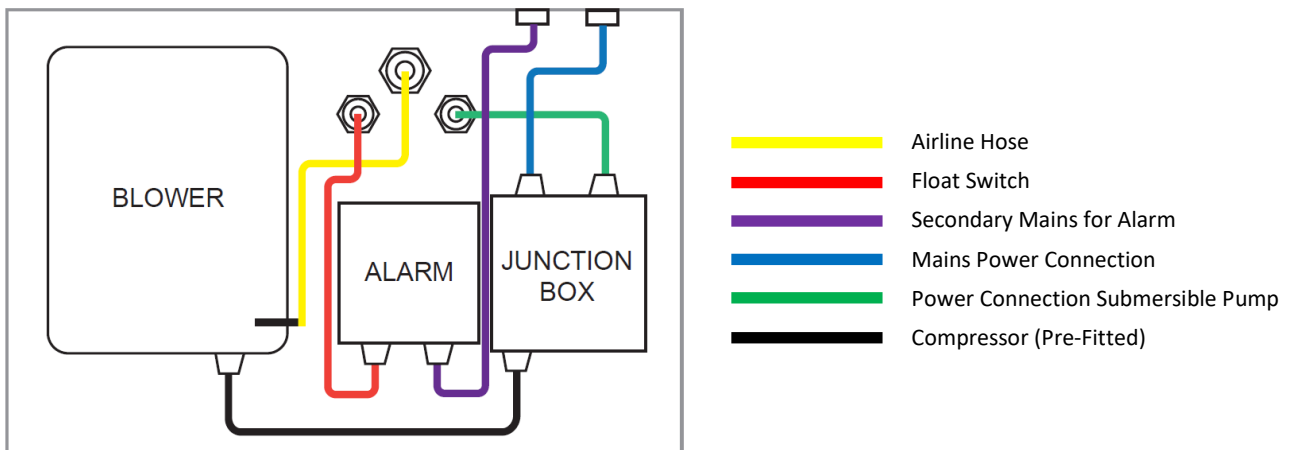

**Figure 15:** Connections inside External Air Blower Housing (Pumped Outlet Version)

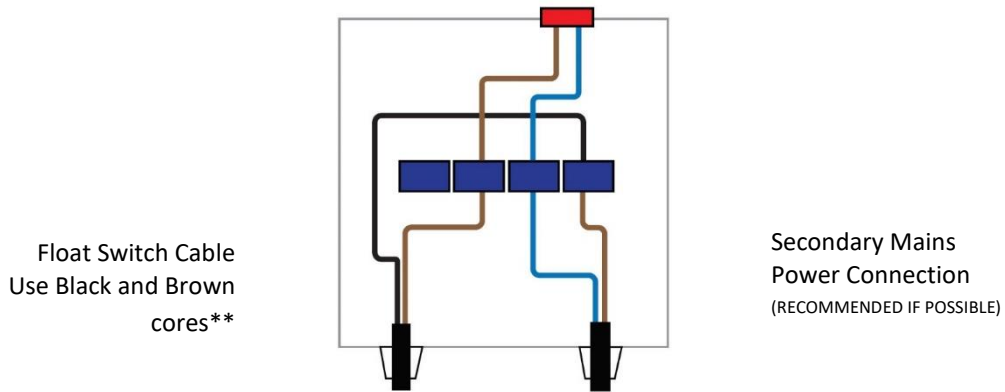

Figure 16: Wiring Connections inside Alarm box (Pumped Outlet Version)

**Ventilation**

It is important that a specific air venting point is provided by the installer to allow the system to freely vent and disperse gas. For a single or double dwelling (6 to 12 POP), this should be achieved through the installation of a soil stack running to the top ridge of the dwelling(s), this must not terminate at eve height. The air from the system must be allowed to freely vent back the inlet pipe from the tank to this soil stack. The internal pipe work of the tanks allows ventilation from all chambers to the inlet pipe work. The soil stack can usually be installed through vertical extension of the dwelling’s wastewater pipe where it leaves the building.

On larger population systems (20 POP+), a remote vent stack should be installed terminating in an appropriate location (fitted on 12 Pop unit as alternative venting option)

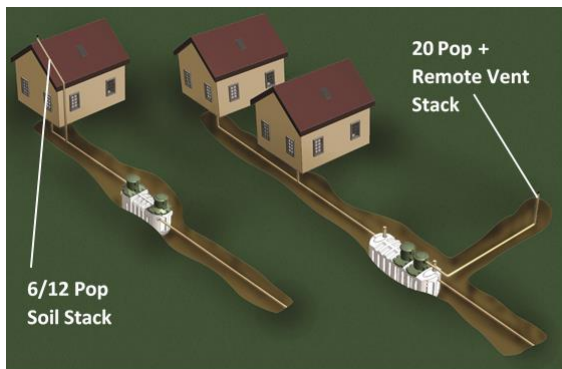

Figure 17: Ventilation

This is connected into the remote vent connection position on the vessel turret using the supplied 110mm grommet connection (see Figure 12 above for image). The remote vent must be positioned at a suitable distance and height from any surrounding dwellings to allow dispersal of air from the system. Consideration should be given to the prevailing wind and any local site geography that might inhibit air dispersion. If in doubt as to the installation of an appropriate vent, please contact Harlequin Tanks for advice.

**Operating Instructions**

**Operating principle and features**

The Harlequin HydroClear is a biological aeration treatment plant designed to produce high effluent quality for safe discharge. It has several functions that minimise the amount of maintenance required for the system. These include:

- A large Primary Treatment chamber that minimises the requirement for desludging
- A Moving Bed Biofilm Reactor (MBBR) biological system that maximises bacterial growth without the potential for clogging in the system
- The bacteria receive a high quality air supply and are mixed and aerated by the high volume fine bubble diffuser.
- There are no mechanical moving parts or electrical components within the tank (excluding Pumped Outlet versions). All functions are operated by air power generated by a linear diaphragm pump (air blower) housed in the external box. This allows safe and easy maintenance

**Process description**

Wastewater enters the first of three chambers, the Primary, where settlement takes place with the heaviest solids sinking and the floating matter rising. These solids are retained and stored in this chamber where anaerobic bacteria, ie, bacteria which do not utilise oxygen, break down the organic matter.

The clarified water is transferred to the aeration chamber where it is mixed with freely moving plastic media elements. The media elements support large bacterial populations over their surfaces which are mixed with the water in the chamber.

Through contact with the bacteria, the organic and nutrient constituents of the water are removed. The chamber is continuously aerated by a fine bubble diffuser which provides the oxygen to nourish the bacteria. The air blower which drives the bubble diffuser is easily accessed for maintenance in the housing atop the plant.

The treated water finally flows through into a smaller final settlement chamber where any sloughed off

## HARLEQUIN HYDROCLEAR INSTALLATION AND OPERATING INSTRUCTIONS

bacteria or escaping solids are collected. The final effluent will either flow by gravity through the 4" Water Pipe outlet or will be pumped out through the 50mm MDPE connection by a submersible pump (Optional

Pumped Outlet version). From here the completely treated water flows to the outlet where it is discharged back into the environment either directly to a water course or through an underground drainage field.

### Process description key

1	110-160mm inlet depending on model
2	Primary Settlement chamber
3	Aeration chamber
4	Final Settlement chamber
5	110-160mm outlet (50mm MDPE Adaptor fitting in Pumped Outlet version)
6	160mm capped lid: desludge point
7	Clark Drain Inspection Cover
8	External Air Pipe Connection (see Fig 10)
9	Clark Drain Cover (Access to Pump in Pumped Outlet Models)
10	160mm capped lid: desludge point
11	Bio media
12	Bubble diffuser

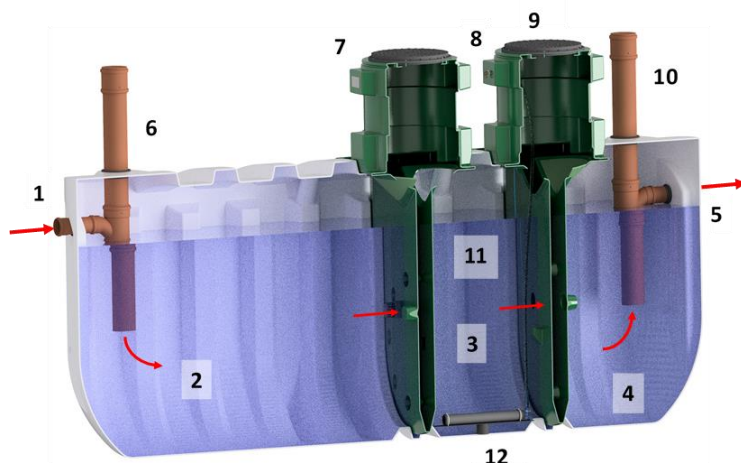

Figure 18: Process Description - HydroClear 12. (Air Blower & Electrics housed externally)

### Components inside the tank

There are no electro/mechanical moving parts within the plant, making the system very reliable and simple to maintain.

The air bubble diffuser in the reactor vessel can be extracted through the main access turret using the rope provided. Rodding access is also provided on all pipework as per normal Building Control guidelines for underground drainage. All other components for the tank can now be found inside the External Blower box

### Plant selection

The tank selection table below indicates plant sizes to suit population requirements

Tank	Population Served	Max flow loading per day (L)
HydroClear 6	1 – 6 people	900
HydroClear 8	7 – 8 people	1200
HydroClear 12	9 – 12 people	1800
HydroClear 20	13 – 20 people	3000
HydroClear 30	21 – 30 people	4500
HydroClear 40	31 – 40 people	6000
HydroClear 50	41 – 50 people	7500

NB: Inlet and outlet pipework 110mm dia (6, 12 and 20 pop) and 160mm dia (30 pop+).

The Harlequin HydroClear is designed for domestic use and is unsuitable for industrial purposes.

### Plant Start Up

1. Fill the plant with clean water until there is a discharge from the outlet.

2. Check all the airline connections are connected per the instructions on Pages 9-10 to ensure air tightness
3. Check the blower ventilation is unobstructed.
4. Turn on the main power supply to the blower unit.
5. Turn the isolator switch inside the External blower housing to the on position. This will start the blower running.
6. It will take a minute or so for the pressure to build up in the system depending on the distance of the blower from the treatment plant.
7. Check that bubbles are breaking the surface in the filter media section of the treatment plant.
8. If a discharge pump is fitted in the final settlement area, check for operation.
9. Refit all manhole covers and lock if necessary.

The wastewater treatment system is now in an operational state. However, the treatment process relies on the growth of microorganisms on the filter media. The time taken for these naturally occurring organisms to develop is dependent on temperature and may take up to six weeks in winter.

Until the biomass is fully developed, the treatment process will be incomplete. During this time do not allow any strong cleaning agents or bleaches to enter the system.

### Plant Shut Down

Short temporary absences of flow to the plant will not be detrimental as sludge levels within the primary settlement should maintain the micro-organisms until flow returns. However, if the flow of sewage to the plant will be interrupted for more than two weeks, the following procedure should be completed:

1. Desludge the primary and final settlement tank compartments in accordance with the instructions below.
2. Refill the plant with clean water.
3. Fit the manhole cover and lock if necessary.
4. Stop the blower by turning the isolator switch to off.
5. Switch off the power supply to the blower enclosure.

### Desludging and Servicing

As with any packaged treatment plant, it is extremely important that the HydroClear is desludged and serviced at the prescribed intervals so that the maximum working life of the components is obtained and that effluent quality does not deteriorate.

Servicing and desludging should be carried out in accordance with the information below depending on the size of the plant.

#### Desludging

It is a requirement of the product warranty that desludging is performed at the required intervals. Proof of desludging, in the form of invoices clearly showing the desludging date, may be required. Failure to carry out regular desludging may affect your Harlequin product warranty. Failure to desludge the system at the appropriate time may cause excessive solids to build up. This could result in solids washout which can pollute water courses or block soakaway systems.

Please refer to Figure 19 below for the location of the desludge points. Harlequin recommends that during all desludge operations, the primary and final settlement chambers should both be emptied but it is possible to reduce the frequency of emptying the FST based on sludge levels. The primary settlement chamber should always be emptied first to avoid excess transfer of solids through the aeration chamber.

*NB: It is important NOT to desludge the aeration chamber which contains the active bacteria affixed to the media*

**Once desludging is complete the plant should be refilled immediately with water (waste or clean) to re-balance internal and external pressures on the plant.**

#### Desludging intervals

HC 6 & HC8	- 12 months
HC 12	- 9 months
HC 20, 30, 40 & 50	- 6 months

The desludging interval may be extended on sites where lower solid concentrations exist (ie a plant is not meeting its full utilisation). A sludge gauge is included with tanks

(HC12 +) to measure sludge levels in the tank(s) and to maximise desludging intervals (recommended max interval of 2 years) Contact Harlequin Manufacturing for further information.

### HydroClear desludge gauge

#### Identification

The Desludge gauge is a 2.3m long clear tube with a sludge marker line and manually operated foot valve. The length of the tube allows the gauge to be positioned at the base of the primary tank from ground level, collecting a core sample of the tank contents upon closing the valve.

This tube then allows the user to determine if the sludge level in the tank is above or below the recommended maximum sludge depth of the tank (700mm).

#### Location

The Desludge gauge is stored securely within the HydroClear body during shipment. It should be removed and stored securely prior to installation. If it is not removed at the time of installation, it can be easily accessed for use at any time.

#### HydroClear 12 & HydroClear 20

The gauge is located under the blank access cover. The gauge is retained between the two skins of the chamber baffle immediately below the blank cover.

#### HydroClear 30, HydroClear 40 & HydroClear 50

The gauge is located under the blank access cover on the Primary tank (1 of 2, 1 of 3 for HC50). The gauge is retained between the two skins of the chamber baffle immediately below the blank cover.

#### Instructions for use

1. Fully open the foot valve on the end of the gauge (the handle is to be rotated in line with the tube)
2. Ensure the valve rope is attached to both the valve handle and the top end of the gauge
3. Slowly insert the gauge, valve end first, into the primary tank until it reaches the vessel base
4. Holding the gauge firmly, pull the valve rope to close the foot valve
5. Extract the gauge from the tank, taking care to keep the gauge in the vertical position at all times
6. Position the gauge in the vertical position and allow five minutes for the contents to settle
7. Examine the depth of darker sludge in the lower end of the tube and measure
8. If the sludge level is above 700mm, then the tank should be desludged
9. Please ensure that the Biological reactors are not desludged. Do NOT desludge through the Rodding Access points circled in red in Figure 19
10. If desludging is required, the plant should be refilled immediately with water (waste or clean) to re-balance internal and external pressures on the plant. This can be done by using a hosepipe or by running several taps in the household(s)

## Desludge Points

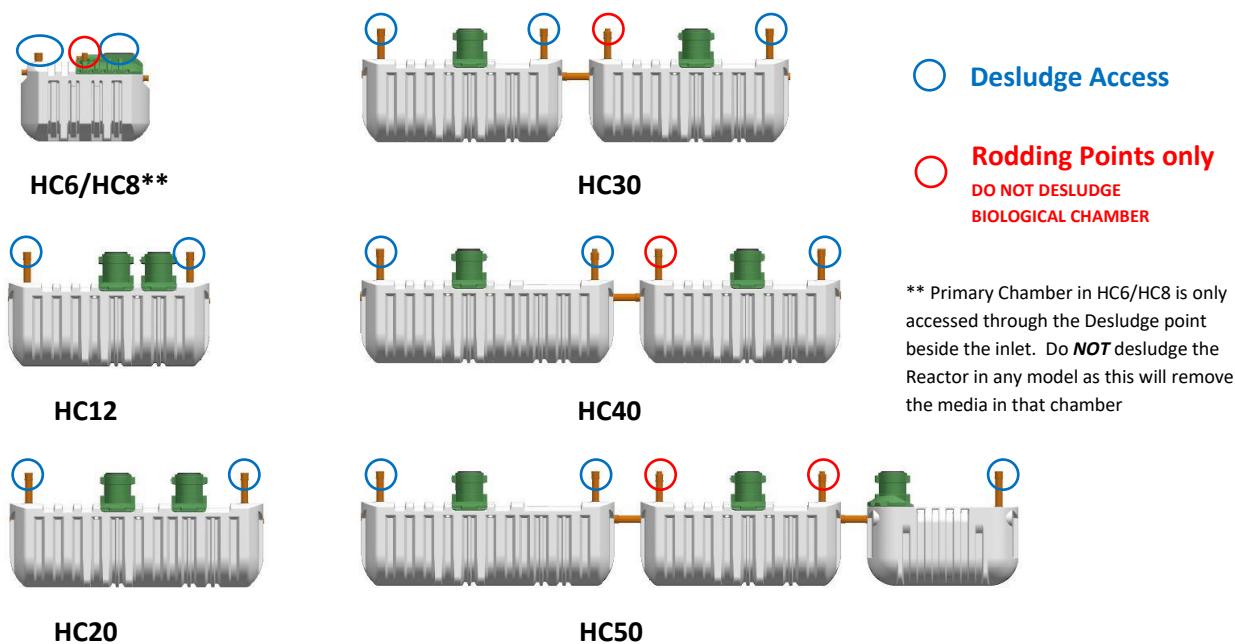

Figure 19: Desludge and Rodding Access points on HydroClear range

## Warranty Provisions

It is ultimately the customer/house owners' responsibility to ensure that their drainage and sewage treatment system complies with all statutory requirements.

Harlequin Manufacturing cannot guarantee the quality of effluent produced as we cannot control what enters the plant. The warranty policy covers the plant only and does not cover or guarantee an effluent quality. Soakaways, drains and the emptying of primary tanks remain the responsibility of the treatment plant owner.

The plant will have a 2 year extended warranty (if the product is registered with Harlequin – 1 year otherwise) that is valid from the date of sale – this warranty covers the body of the tanks and ancillary equipment (excluding consumables), where a replacement will be delivered to site. This is subject to the tank being installed correctly according to the instructions listed in this guide and the servicing requirements being met. The warranty does not cover anything before or after the tank i.e. soak away, drainage, venting and it does not cover damage done to the plant by any other product within the system.

If a Harlequin Wastewater Treatment Plant arrives on site damaged, it is to be reported by the end user / installer at the time of delivery/installation.

It is the installer's responsibility to check the plant internally for damage. It is also the installer's responsibility for the electrical supply, safety, connection, suitability and testing non-interference with other electrical systems as well as the ducting, hoses, venting and sealing.

The plant is not designed to have any non-biological waste going into the tank and is not suitable for any waste out with the plants design parameters. If a fault develops with the tank due to unsuitable waste entering the system this is not covered by the warranty agreement.

To ensure that the plant continues to operate efficiently, your attention is drawn to the following points:

DO NOT exceed the maximum design loading of the plant.

DO NOT allow surface water to enter the system.

DO NOT allow high volume discharges such as from swimming pools or Jacuzzis to enter the system.

DO NOT allow large quantities of non-biological waste/chemicals such as water softeners, disinfectants, strong acids or alkalis, oil and grease, pesticides or photographic chemicals to enter the system.

DO NOT use chemical or biological emulsifiers in grease traps.

DO NOT allow fats, oil or grease from catering applications to enter the system

## Maintenance Schedule:

- Check the operation of the blower. If the blower has failed for any reason other than a mains power failure the warning beacon will be flashing.
- Check the operation of the diffusers (bubbles rising in the Biological zone).
- Check the inlet and outlet stilling zones are clear of debris. (Remove any obstructions).

- Check the blower ventilation is un-obstructed.
- Check the biomass growth on the filter media. The biomass should be a light brown colour, not white or grey. The odour in the plant should be 'earthy'. There should not be a noticeable 'rotten eggs' smell.
- Check the final effluent. If this is cloudy or contains many suspended particles, then the final settlement tank is likely to require desludging.

**Filters:** It is a recommendation that the air blower filter be checked/cleaned/replaced (if necessary) every 3 months, particularly on sites which are prone to dusty conditions. Service kits and instructions for the checking/replacement of a filter are available on request. The warranty on the blower unit is subject to the filter quality being maintained.

**Diaphragms:** The working life of the diaphragm depends on the operating conditions and the work environment but for optimal operation, it would be recommended to change both parts every 12 months. The warranty on the blower unit is subject to the diaphragm being maintained. Diaphragms kits and instructions are available on request.

**Valve Boxes:** It is recommended by the manufacturer that these covers are replaced every three years to maintain optimum performance.

### 24-monthly intervals

A full service on the plant should be performed. The service should ensure that all aspects of the system are functioning correctly.

Particular areas of detail include:

- Checking all chambers for damage
- Checking the full air system including the air blower and diffusers
- Checking lid seals and air blower chamber
- Checking ventilation system
- Checking electrical connections at the plant.

### FINAL INSTALLATION CHECK LIST

- |  |                          |
|--|--------------------------|
| Tank Installed correct distance from property  | <input type="checkbox"/> |
| Tank installed on a flat concrete base   | <input type="checkbox"/> |
| Reactor/Media Chamber filled with water before Primary Chamber (Pop 6/8 models ONLY)   | <input type="checkbox"/> |
| Tank backfilled with pea-gravel in "dry" ground conditions                             | <input type="checkbox"/> |
| Tank backfilled with concrete in "wet" ground conditions                               | <input type="checkbox"/> |
| Air hose cut to length and connected to blower box and tank connections securely       | <input type="checkbox"/> |
| Perforated metal straps securing blower removed prior to use                           | <input type="checkbox"/> |
| Electrical installation completed and Air blower running                               | <input type="checkbox"/> |
| Check Diffuser is in correct position with air bubbles passing up through media evenly | <input type="checkbox"/> |
| Customer has been advised on desludging and servicing of tank                          | <input type="checkbox"/> |
| Customer has been given copy of Installation and Servicing Guide                       | <input type="checkbox"/> |

### Pumped Outlet Version:

- |  |                          |
|--|--------------------------|
| Secondary power supply for High level alarm (recommended)                    | <input type="checkbox"/> |
| Ensure Submersible pump starts operating as float rises above pump           | <input type="checkbox"/> |
| Ensure Pump turns off as liquid level lowers below top of pump               | <input type="checkbox"/> |
| Ensure high level alarm operates if water level rises towards top of chamber | <input type="checkbox"/> |

## Fault Finding

Symptom	Cause	Action (all work must be performed by a specialized company)
Strong smell	Blocked or damaged air diffuser	Remove the diffuser; clean or replace if necessary
	Blocked or damaged air hose	Change the damaged hose, unblock it if necessary
	Kinks/bends in the air hose	Change damaged air hose
	Air escaping from joints	Check connections and tighten them if necessary
	The joints of the pipes are damaged	Check and replace the seals if necessary
	The air diffuser is no longer at the bottom of the tank	Re-Install the diffuser at the bottom of the tank, replace the weight if necessary
	High sludge level	Arrange a desludging of the tank
	The diaphragm of the compressor is damaged	Replace the diaphragm
The treated water is of poor quality	The air diffuser is clogged or torn	Remove the diffuser; clean or replace if necessary
	Blocked or damaged air hose	Change the damaged hose, unblock it if necessary
	Kinks/bends in the air hose	Change damaged air hose
	Air escaping from joints	Check connections and tighten them if necessary
	There is an organic overload because of the use of garbage grinders	Compost biological wastes
	High sludge level	Arrange a desludging of the tank
	There is no power supply	Check power
	The diaphragm of the compressor is damaged	Replace the diaphragm
Treated water contains large amounts of solids	High sludge level	Arrange a desludging of the tank
	Excessive use of the washing machine	Minimise continuous use of equipment that will dispose to the tank
Fat build up within the tank	Excessive use of the washing machine	Minimise continuous use of equipment that will dispose to the tank
	Excessive fatty components coming to tank through waste streams	Separate fatty waste streams and minimise amounts going to tank
	The air diffuser is clogged or torn	Remove the diffuser; clean or replace if necessary
	Blocked or damaged air hose	Change the damaged hose, unblock it if necessary
	Kinks/bends in the air hose	Change damaged air hose
	Air escaping from joints	Check connections and tighten them if necessary
High water level (above the pipes)	Blockage in the pipes	Clean all pipes (Inlet, outlet and inside the tank where possible)
Compressor warning	Issue with the compressor	Check the power supply, the diaphragm and air filter. Replace/repair if necessary
Higher Noise Levels	Issue with the compressor	Ensure that the perforated metal straps holding the unit down within the external compressor housing have been removed
		Check the diaphragm is not damaged



Appendix 1: EN12566 Certification:



# TREATMENT PERFORMANCE RESULTS

**Clarehill Plastics Ltd.**

21 Clarehill Road, BT670PB, Moira, County Armagh, Great Britain

**EN 12566-3**

Results corresponding to EN 12566-3 and S.R. 66

PIA-SR66-1603-1039

**HydroClear**

Biological aerated moving media process

Nominal organic daily load	0.38 kg/d		
Nominal hydraulic daily load	1.20 m <sup>3</sup> /d		
Material	Polyethylene		
Watertightness	Pass		
Structural behaviour (Pit Test)	Pass (also wet conditions)		
Durability	Pass		
Treatment efficiency (nominal sequences)		Efficiency	Effluent
		COD	91.2 %
		BOD <sub>5</sub>	96.6 %
		NH <sub>4</sub> -N	85.8 %
		SS	94.7 %
			59 mg/l
			11 mg/l
			4.5 mg/l
			19 mg/l
Number of desludging	Not more than once		
Electrical consumption	1.8 kWh/d		

Performance tested by:

**PIA – Prüfinstitut für Abwassertechnik GmbH**

(PIA GmbH)

Hergentrather Weg 30

52074 Aachen, Germany

This document replaces neither the declaration of performance nor the CE marking.



Notified Body  
No.: 1739



Certified according to  
ISO 9001:2008



Elmar Lancé

July 2016

## Appendix 2: HydroClear MK-II Installation Guidelines

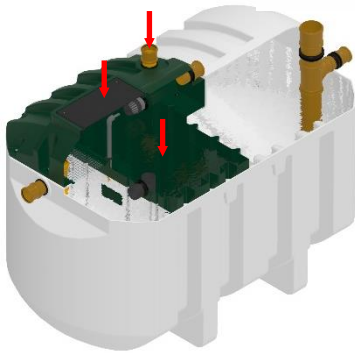
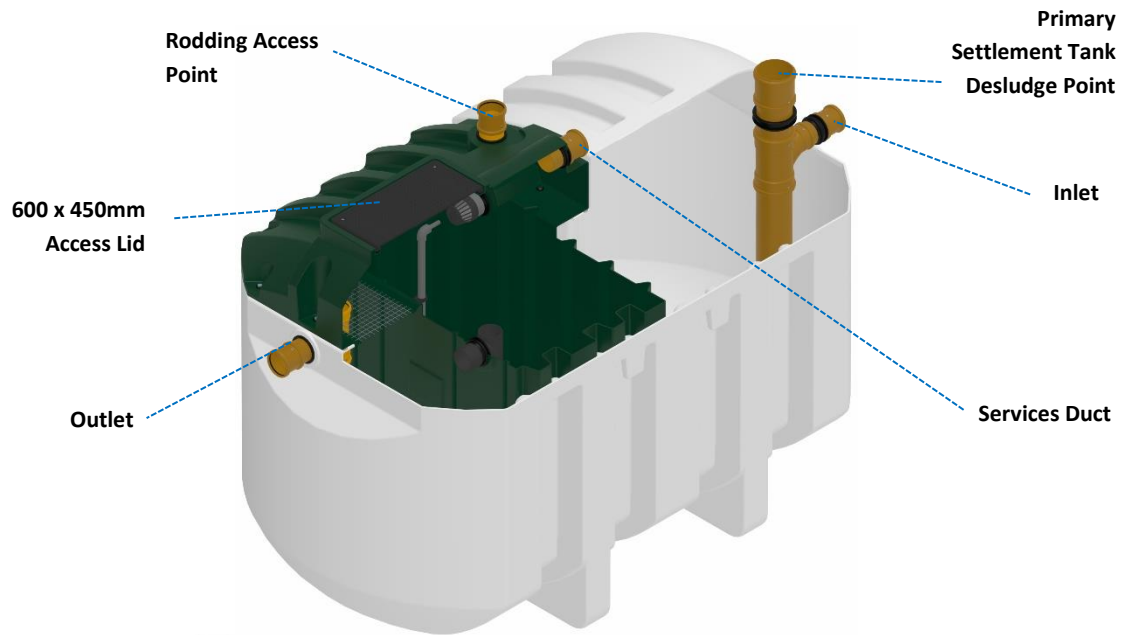

- Once tank has been lowered onto concrete base, fill the reactor chamber first through the 450mm x 600mm manway access lid or through the Rodding Access Point for that Chamber. This **MUST** be carried out first to prevent damage to the tank

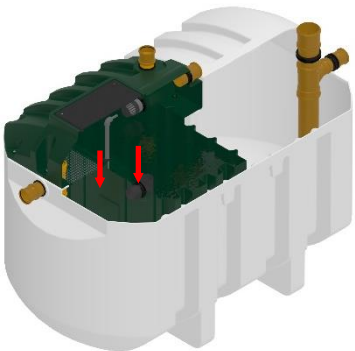

- When Reactor/media chamber has been filled, it will overflow through the weir into the Final Settlement Chamber. You can let this continue or fill directly from the manway access lid

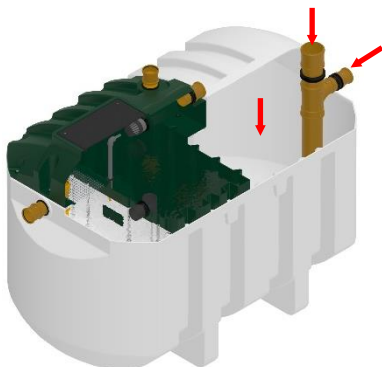

- As the Final Settlement Chamber starts to fill, you can simultaneously start to fill the Primary Settlement Chamber through the primary Desludge Point or the Tank Inlet point

